



since 1921
SINCE 1921



The finest hose clip
in the world

JUBILEE® PROFILE

Jubilee® Clips were manufactured as the first worm drive hose clamp in 1921, the company held the first patent for worm drive hose clips and has been manufacturing hose clips in Great Britain ever since. The name Jubilee® Clip remains a registered trademark throughout the world.

The company now offers a wide range of clamping solutions including small clamps such as two ear 'O' clips and Jubilee® Juniors (nut and bolt clamps), high strength clips such as High Torque and Superclamps, and cut to length banding and strapping systems known as Multiband.

The success of the company is based on the principal foundation of quality. Through both the quality of our products and the quality of our service, we aim to be a company that you can rely on.

QUALITY

Jubilee® Clips are manufactured to the very highest standards, using only premium grade materials. All our product ranges are systematically checked to their various Standards during manufacture and packing.

Jubilee clips are Kitemarked™ to BS 5315:1991, the company is registered to BS EN ISO 9001:2008 Quality Management System and ISO 14001 Environmental Management System. The stainless steel range is also Lloyd's Type Approved, essential when used for marine applications.

All Jubilee® products conform to the latest EU Directives, furthermore we aim to work in a socially, ethically and environmentally responsible way ensuring that our manufacturing processes conform to environmental legislation. We continue to decrease the effect that our manufacturing output has on the environment and improve our packaging waste year on year, recycling as much as possible.



CORROSION RESISTANCE NSS TEST

Jubilee Clips conduct Neutral Salt Spray tests (NSS) according to BS EN ISO 9227 2006. The NSS test is conducted in a sealed chamber at 35°C, where a 5% NaCl solution with a PH value of between 6.5 and 7.2 is sprayed continuously onto the clips. The duration of time shown in this product brochure shows the minimum number of hours the clips are able to withstand the salt spray test without significant signs of corrosion (red rust formation).

It is difficult to transfer this information to a length of time the clips would survive in an application under normal environmental conditions, as these will vary from one location to the next. 240 hours is regarded by the British construction industry as the equivalent of a lifetime of 60 years in an urban outside environment in the UK.

ORIGINAL RANGE

The original Jubilee® Clip, the product that started it all! For the vast majority of applications this sturdy worm drive hose clip is ideally suited. Available as a mild steel zinc protected or stainless steel clamp in both 304 (18/8) and 316 (18/10) grades of stainless steel; this product also has a band that is continuously threaded enabling extra flexibility when adjusting the clip to the correct size. The smooth inside profile of the band and rolled edges give protection for all types of hoses including soft hoses made from rubber or silicone.

All our original Jubilee® Clips are independently tested by the British Standards Institute (BSI) and carry the British Standard Kitemark™, which is universally regarded as the most stringent Standard there is for a hose clip. Both grades of stainless steel clips are also accredited by Lloyd's Register for marine use.

For our ranges of worm drive hose clips, Jubilee® never use mixed materials, as this ensures highest levels of corrosion resistance, whereas when using mixed materials, such as in W2 hose clips, one material will be sacrificed in favour of another and will corrode much quicker than when only one material is used.

Available in:-

Mild Steel Zinc Protected

304 Stainless Steel

316 Stainless Steel



Industry Recommended Symbols:-

- Agricultural
- Automotive
- Food
- Hardware/DIY
- Industrial
- Marine
- Oil/Gas
- Ventilation
- Electrical

ORIGINAL RANGE

Mild Steel Zinc Protected:-



Original Range Jubilee® Clips in zinc protected mild steel are the most popular clips in our range. Ideally suited for most day to day requirements for joining hose in areas such as the automotive industry and the automotive aftermarket, agricultural applications, such as irrigation and farm machinery, pneumatic and hydraulic applications in the industrial sector, hardware/DIY applications and in construction.

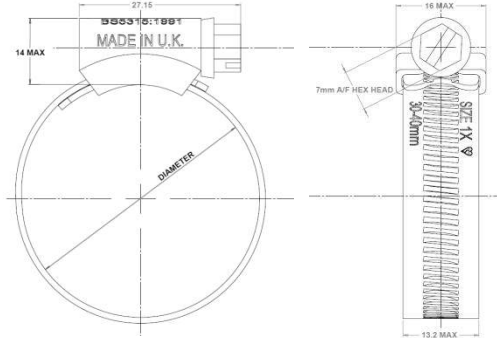

Part No.	BS No.	Adjustment mm	Adjustment Inches	Band Width mm	Band Thickness mm	Recommended Torque Nm	Maximum Torque Nm	Maximum Pressure PSI	Part No.
00OMS	12	9.5- 12	3/8- 1/2	9.9	0.762	3.4	4.5	203	00OMS
M0OMS	16	11- 16	1/2-5/8	9.9	0.762	3.4	4.5	203	M0OMS
0OMS	20	13- 20	1/2-3/4	9.9	0.762	3.4	4.5	203	0OMS
OMS	22	16- 22	5/8- 7/8	13.0	0.914	4.2	5.6	203	OMS
OXMS	25	18- 25	3/4-1	13.0	0.914	4.2	5.6	203	OXMS
1AMS	30	22- 30	7/8-1 1/8	13.0	0.914	5.1	6.8	203	1AMS
1MS	35	25- 35	1-1 3/8	13.0	0.914	5.1	6.8	102	1MS
1XMS	40	30- 40	1 1/8-1 5/8	13.0	0.914	5.1	6.8	102	1XMS
1MMS	45	32- 45	1 1/4-1 3/4	13.0	0.914	5.1	6.8	102	1MMS
2AMS	50	35- 50	1 3/8-2	13.0	0.914	5.9	7.9	102	2AMS
2MS	55	40- 55	1 5/8-2 1/8	13.0	0.914	5.9	7.9	102	2MS
2XMS	60	45- 60	1 3/4 -2 3/8	13.0	0.914	5.9	7.9	102	2XMS
3MS	70	55- 70	2 1/8-2 3/4	13.0	0.914	6.7	9	102	3MS
3XMS	80	60- 80	2 3/8-3 1/8	13.0	0.914	6.7	9	44	3XMS
4MS	90	70- 90	2 3/4-3 1/2	13.0	0.914	6.7	9	44	4MS
4XMS	100	85-100	3 1/4-4	13.0	0.914	6.7	9	44	4XMS
5MS	120	90-120	3 1/2-4 3/4	13.0	0.914	6.7	9	44	5MS
6MS	140	110-140	4 3/8-5 1/2	13.0	0.914	6.7	9	44	6MS
6XMS	150	120-150	4 3/4-5 7/8	13.0	0.914	6.7	9	18	6XMS
7MS	165	135-165	5 1/4-6 1/2	13.0	0.914	5.9	7.9	18	7MS
7.5MS	190	158-190	6 1/4-7 1/2	13.0	0.914	5.9	7.9	18	7.5MS
8.5MS	216	184-216	7 1/4-8 1/2	13.0	0.914	5.9	7.9	18	8.5MS
9.5MS	242	210-242	8 1/4-9 1/2	13.0	0.914	5.9	7.9	18	9.5MS
10.5MS	267	235-267	9 1/4-10 1/2	13.0	0.914	5.9	7.9	18	10.5MS
11.5MS	292	260-292	10 1/4-11 1/2	13.0	0.914	5.9	7.9	18	11.5MS
12.5MS	318	286-318	11 1/4-12 1/2	13.0	0.914	5.9	7.9	18	12.5MS

For larger sizes please contact us

Corrosion Resistance: 240 hours NSS Test

Fastening: 7mm A/F screw

Industry Recommendations:-

Quality Assurance:-



**The finest hose clip
in the world**

Mild Steel Zinc Protected



ORIGINAL RANGE 304 Stainless Steel:-



The most versatile of clips in the Jubilee® range, our Original Range Jubilee® hose clips in 304 (18/8) stainless steel are widely used across all industries where hose clips are used to secure hoses, as well as for other applications. Their corrosion resistance enables their use in the marine, oil and gas and food sectors, as well as the agricultural, hardware and industrial sectors, where higher corrosion resistance is required.



Part No.	BS No.	Adjustment mm	Adjustment Inches	Band Width mm	Band Thickness mm	Recommended Torque Nm	Maximum Torque Nm	Maximum Pressure PSI	Part No.
000SS	12	9.5- 12	3/8- 1/2	9.9	0.762	3.4	4.5	203	000SS
MO0SS	16	11- 16	1/2-5/8	9.9	0.762	3.4	4.5	203	MO0SS
00SS	20	13- 20	1/2-3/4	9.9	0.762	3.4	4.5	203	00SS
0SS	22	16- 22	5/8- 7/8	13.0	0.914	4.2	5.6	203	0SS
0XSS	25	18- 25	3/4-1	13.0	0.914	4.2	5.6	203	0XSS
1ASS	30	22- 30	7/8-1 1/8	13.0	0.914	5.1	6.8	203	1ASS
1SS	35	25- 35	1-1 3/8	13.0	0.914	5.1	6.8	102	1SS
1XSS	40	30- 40	1 1/8-1 5/8	13.0	0.914	5.1	6.8	102	1XSS
1MSS	45	32- 45	1 1/4-1 3/4	13.0	0.914	5.1	6.8	102	1MSS
2ASS	50	35- 50	1 3/8-2	13.0	0.914	5.9	7.9	102	2ASS
2SS	55	40- 55	1 5/8-2 1/8	13.0	0.914	5.9	7.9	102	2SS
2XSS	60	45- 60	1 3/4 -2 3/8	13.0	0.914	5.9	7.9	102	2XSS
3SS	70	55- 70	2 1/8-2 3/4	13.0	0.914	6.7	9	102	3SS
3XSS	80	60- 80	2 3/8-3 1/8	13.0	0.914	6.7	9	44	3XSS
4SS	90	70- 90	2 3/4-3 1/2	13.0	0.914	6.7	9	44	4SS
4XSS	100	85-100	3 1/4-4	13.0	0.914	6.7	9	44	4XSS
5SS	120	90-120	3 1/2-4 3/4	13.0	0.914	6.7	9	44	5SS
6SS	140	110-140	4 3/8 -5 1/2	13.0	0.914	6.7	9	44	6SS
6XSS	150	120-150	4 3/4 -5 7/8	13.0	0.914	6.7	9	18	6XSS
7SS	165	135-165	5 1/4 -6 1/2	13.0	0.914	5.9	7.9	18	7SS
7.5SS	190	158-190	6 1/4 -7 1/2	13.0	0.914	5.9	7.9	18	7.5SS
8.5SS	216	184-216	7 1/4 -8 1/2	13.0	0.914	5.9	7.9	18	8.5SS
9.5SS	242	210-242	8 3/4 -9 1/2	13.0	0.914	5.9	7.9	18	9.5SS
10.5SS	267	235-267	9 1/4 -10 1/2	13.0	0.914	5.9	7.9	18	10.5SS
11.5SS	292	260-292	10 1/4 -11 1/2	13.0	0.914	5.9	7.9	18	11.5SS
12.5SS	318	286-318	11 1/4 -12 1/2	13.0	0.914	5.9	7.9	18	12.5SS

For larger sizes please contact us

Corrosion Resistance: 1000 hours NSS Test

Fastening: 7mm A/F screw

Industry Recommendations:-

Quality Assurance:-



304 Stainless Steel

ORIGINAL RANGE 316 Stainless Steel (HNSS):-



The Original Range Jubilee® hose clips with the highest corrosion resistance, our 316 (18/10) stainless steel Jubilee® clips, are the hose clip of preference in shipbuilding and maintenance when the highest level of corrosion resistance is demanded. Other areas where our Original Range 316 stainless steel clips are used are the food and chemicals industries, where highly corrosive acids can be present, and this material grade is also favoured by the oil and gas industry.

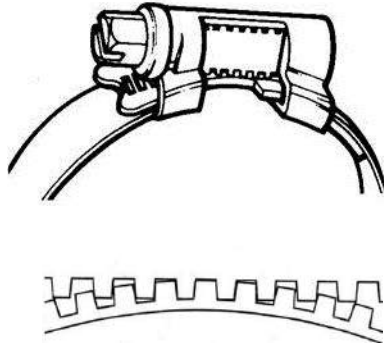

Part No.	BS No.	Adjustment mm	Adjustment Inches	Band Width mm	Band Thickness mm	Recommended Torque Nm	Maximum Torque Nm	Maximum Pressure Psi	Part No.
000SS316	12	9.5- 12	3/8- 1/2	9.9	0.762	3.4	4.5	203	000SS316
M00SS316	16	11- 16	1/2-5/8	9.9	0.762	3.4	4.5	203	M00SS316
00SS316	20	13- 20	1/2-3/4	9.9	0.762	3.4	4.5	203	00SS316
0SS316	22	16- 22	5/8- 7/8	13.0	0.914	4.2	5.6	203	0SS316
0XSS316	25	18- 25	3/4-1	13.0	0.914	4.2	5.6	203	0XSS316
1ASS316	30	22- 30	7/8-1 1/8	13.0	0.914	5.1	6.8	203	1ASS316
1SS316	35	25- 35	1-1 3/8	13.0	0.914	5.1	6.8	102	1SS316
1XSS316	40	30- 40	1 1/8-1 5/8	13.0	0.914	5.1	6.8	102	1XSS316
1MSS316	45	32- 45	1 1/4-1 3/4	13.0	0.914	5.1	6.8	102	1MSS316
2ASS316	50	35- 50	1 3/8-2	13.0	0.914	5.9	7.9	102	2ASS316
2SS316	55	40- 55	1 5/8-2 1/8	13.0	0.914	5.9	7.9	102	2SS316
2XSS316	60	45- 60	1 3/4 -2 3/8	13.0	0.914	5.9	7.9	102	2XSS316
3SS316	70	55- 70	2 1/8-2 3/4	13.0	0.914	6.7	9	102	3SS316
3XSS316	80	60- 80	2 3/8-3 1/8	13.0	0.914	6.7	9	44	3XSS316
4SS316	90	70- 90	2 3/4-3 1/2	13.0	0.914	6.7	9	44	4SS316
4XSS316	100	85-100	3 1/4-4	13.0	0.914	6.7	9	44	4XSS316
5SS316	120	90-120	3 1/2-4 3/4	13.0	0.914	6.7	9	44	5SS316
6SS316	140	110-140	4 3/8-5 1/2	13.0	0.914	6.7	9	44	6SS316
6XSS316	150	120-150	4 3/4-5 7/8	13.0	0.914	6.7	9	18	6XSS316
7SS316	165	135-165	5 1/4-6 1/2	13.0	0.914	5.9	7.9	18	7SS316
7.5SS316	190	158-190	6 1/4-7 1/2	13.0	0.914	5.9	7.9	18	7.5SS316
8.5SS316	216	184-216	7 1/4-8 1/2	13.0	0.914	5.9	7.9	18	8.5SS316
9.5SS316	242	210-242	8 1/4-9 1/2	13.0	0.914	5.9	7.9	18	9.5SS316
10.5SS316	267	235-267	9 1/4-10 1/2	13.0	0.914	5.9	7.9	18	10.5SS316
11.5SS316	292	260-292	10 1/4-11 1/2	13.0	0.914	5.9	7.9	18	11.5SS316
12.5SS316	318	286-318	11 1/4-12 1/2	13.0	0.914	5.9	7.9	18	12.5SS316

For larger sizes please contact us

Corrosion Resistance: 2000 hours NSS Test

Fastening: 7mm A/F screw

Industry Recommendations:-

Quality Assurance:-



316 Stainless Steel

**The finest hose clip
in the world**



HIGH TORQUE

Jubilee High Torque Clips are suitable for heavy duty applications with plastic or reinforced hoses. The high clamping forces make this clip suitable for heavy duty applications where stubborn leakage or vibration issues make lesser clips and clamps unsuitable.



Jubilee High Torque clips are made of all stainless steel, with a two part housing and cut through band, keeping the band straight at the point of engagement and fully engaging all of the screw thread; giving a superior tightening torque. Although not suitable for use on soft hoses, where the high forces and perforated band may cut into the hose, they are ideal where a high clamping force is required and with a flexible band material they can achieve a high level of friction even against a smooth surface such as a metal pole.

With a wide clamping range compared to alternative heavy duty clamps, stock requirements are reduced. The flexible band also offers better sealing at lower torques than nut and bolt style heavy duty clamps, which, combined with weight saving benefits, make Jubilee High Torque Clips a versatile and superior heavy duty clamp.

- Conform to SAE J1508 type HD
- 8mm A/F slotted screw
- All stainless steel
- Twice the tightening torque of standard worm drive hose clips which creates more than twice the band tension for stubborn leakage and high vibration applications.
- Breaking torque is 17 Nm comparable to conventional 'T' bolt clips of equal size.
- Recommended tightening torque 11.9 Nm (106 lbs in).
- Appropriate in those heavy duty situations where the general British Standard product is not suitable.

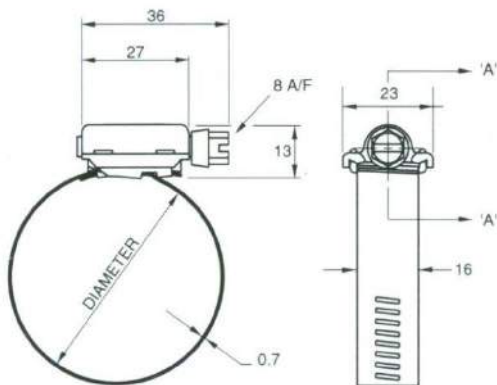

All dimensions in mm

Stainless Steel



HIGH TORQUE Stainless Steel:-



SECTION 'A'- 'A'

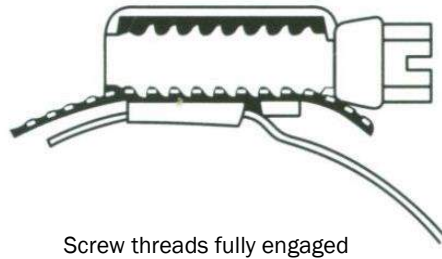

Screw threads fully engaged



Part No.	Adjustment		Band Width mm	Band Thickness mm	Recommended Torque Nm	Maximum Torque Nm	Maximum Pressure Psi	Part No.
	mm	Inches						
HT035	20- 35	3/4-1 ³ / ₈	16.0	0.7	11.9	17.0	304.5	HT035
HT040	25- 40	1-1 ⁵ / ₈	16.0	0.7	11.9	17.0	304.5	HT040
HT045	25- 45	1-1 ³ / ₄	16.0	0.7	11.9	17.0	304.5	HT045
HT050	30- 50	1 ¹ / ₄ -2	16.0	0.7	11.9	17.0	304.5	HT050
HT070	40- 70	1 ⁵ / ₈ -2 ³ / ₄	16.0	0.7	11.9	17.0	153.0	HT070
HT080	60- 80	2 ³ / ₈ -3 ¹ / ₈	16.0	0.7	11.9	17.0	153.0	HT080
HT095	70- 95	2 ³ / ₄ -3 ³ / ₄	16.0	0.7	11.9	17.0	153.0	HT095
HT100	80-100	3 ¹ / ₈ -4	16.0	0.7	11.9	17.0	66.0	HT100
HT120	90-120	3 ¹ / ₂ -4 ³ / ₄	16.0	0.7	11.9	17.0	66.0	HT120
HT140	110-140	4 ³ / ₈ -5 ¹ / ₂	16.0	0.7	11.9	17.0	66.0	HT140
HT160	130-160	5 ¹ / ₈ -6 ¹ / ₄	16.0	0.7	11.9	17.0	66.0	HT160
HT180	150-180	5 ⁷ / ₈ -7	16.0	0.7	11.9	17.0	30.0	HT180
HT200	170-200	6 ³ / ₄ -7 ⁷ / ₈	16.0	0.7	11.9	17.0	30.0	HT200
HT220	190-220	7 ¹ / ₂ -8 ⁵ / ₈	16.0	0.7	11.9	17.0	30.0	HT220
HT240	210-240	8 ³ / ₄ -9 ¹ / ₂	16.0	0.7	11.9	17.0	30.0	HT240
HT260	230-260	9-10 ¹ / ₄	16.0	0.7	11.9	17.0	30.0	HT260
HT280	250-280	9 ⁷ / ₈ -11	16.0	0.7	11.9	17.0	30.0	HT280
HT300	270-300	10 ⁵ / ₈ -11 ³ / ₄	16.0	0.7	11.9	17.0	30.0	HT300
HT320	290-320	11 ³ / ₈ -12 ¹ / ₂	16.0	0.7	11.9	17.0	30.0	HT320
HT340	310-340	12 ¹ / ₄ -13 ³ / ₈	16.0	0.7	11.9	17.0	n/a	HT340
HT360	330-360	13-14 ¹ / ₈	16.0	0.7	11.9	17.0	n/a	HT360
HT380	350-380	13 ³ / ₄ -15	16.0	0.7	11.9	17.0	n/a	HT380
HT400	370-400	14 ¹ / ₂ -15 ³ / ₄	16.0	0.7	11.9	17.0	n/a	HT400
HT420	390-420	15 ³ / ₈ -16 ¹ / ₂	16.0	0.7	11.9	17.0	n/a	HT420
HT440	410-440	16 ¹ / ₈ -17 ¹ / ₄	16.0	0.7	11.9	17.0	n/a	HT440
HT460	430-460	17-18 ¹ / ₈	16.0	0.7	11.9	17.0	n/a	HT460
HT480	450-480	17 ³ / ₄ -18 ⁷ / ₈	16.0	0.7	11.9	17.0	n/a	HT480
HT500	470-500	18 ¹ / ₂ -19 ⁵ / ₈	16.0	0.7	11.9	17.0	n/a	HT500
HT520	490-520	19 ⁵ / ₁₆ -20 ¹ / ₂	16.0	0.7	11.9	17.0	n/a	HT520

Corrosion Resistance: 400 hours NSS Test

Fastening: 8mm A/F screw

Industry Recommendations:-



Quality Assurance:-



Stainless Steel

**The finest hose clip
in the world**



MULTIBAND

Jubilee® Multiband is a self assembly, endless banding or screw band system, which allows the user to cut the band to the desired length.

Used in areas such as heating, ventilation and air conditioning (HVAC), sign fixing, conduit and cable retention and lagging, this product is highly versatile.

The Jubilee® Multiband system comprises a worm drive steel strip that is cut to the length required, and screw housings which slide onto the band. The band can then be tightened onto pipes or ducts of almost any diameter. A number of screw and housing designs and two band widths are available to suit any application.



- Choose Multiband to make a clip to any size.
- Quick, versatile and convenient.
- Simply cut to length, add a housing, insert a screw and tighten to size.



Available in:-

Zinc Plated Mild Steel

304 Stainless Steel

MULTIBAND

Zinc Plated Mild Steel:-

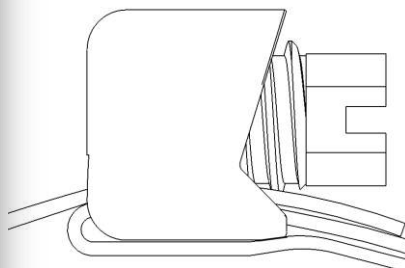

Range	Adjustment mm	Band Width mm	Band Thickness mm	Recommended Torque Nm	Maximum Torque Nm	Maximum Pressure Psi	Range
MB11MS	Cut to length	11.0	0.82	3.4	4.5	n/a	MB11MS

Component Parts for MB11MS:-



Banding in dispensers of 10 m

Part No. **MB1701**

- 11mm wide
- 10 metre roll
- Zinc plated mild steel



Banding in dispensers of 30 m

Part No. **MB1702**

- 11mm wide
- 30 metre roll
- Zinc plated mild steel

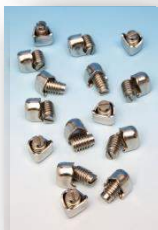

Housings/screws for use with 11mm Multiband

Part No. **MB1703 box of 100**
MB1704 box of 25

- Solid housing
- 7mm A/F hexagonal screw
- Zinc plated mild steel



Captive housings/screws for use with 11mm Multiband

Part No. **MB1706**

- 7mm A/F hexagonal screw
- Box of 25 sets
- Zinc plated mild steel



Housings/Allen screws for use with 11mm Multiband

Part No. **MB1705**

- Solid housing
- 5/16" recess hexagonal key slot
- Box of 100 sets
- Zinc plated mild steel



Handy Pack

Part No. **MB1708**

- 11mm wide
- 10 metre roll
- 25 solid housings/screws
- Zinc plated mild steel

Corrosion Resistance: 240 hours NSS Test

Fastening: 7mm A/F screw

Industry Recommendations:-



Zinc Plated Mild Steel

The finest hose clip
in the world



MULTIBAND 304 Stainless Steel:- 11mm Wide

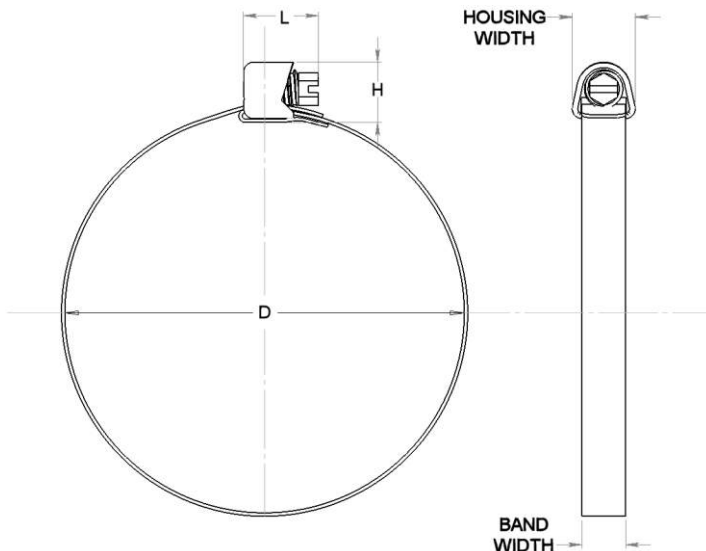

Range	Adjustment mm	Band Width mm	Band Thickness mm	Recommended Torque Nm	Maximum Torque Nm	Maximum Pressure Psi	Range
MB11SS	Cut to length	11.0	0.80	3.4	4.5	n/a	MB11SS

Component Parts for MB11SS:-



Banding In dispensers of 30 m

Part No. **MB1802**

- 11mm wide
- 30 metre roll
- 304 Stainless steel



Handy Pack

Part No. **MB1806**

- 11mm wide
- 10 metre roll
- 25 solid housings/screws
- 304 Stainless steel



Housings/screws for use with 11mm Multiband

Part No. **MB1803**

- Solid housing
- 7mm A/F hexagonal screw
- Box of 100
- 304 Stainless steel



Captive housings/screws for use with 11mm Multiband

Part No. **MB1805**

- 7mm A/F hexagonal screw
- Box of 100 sets
- 304 Stainless steel



Housings/Allen screws for use with 11mm Multiband

Part No. **MB1804**

- Solid housing
- 5/16" recess hexagonal key slot
- Box of 100 sets
- 304 Stainless steel

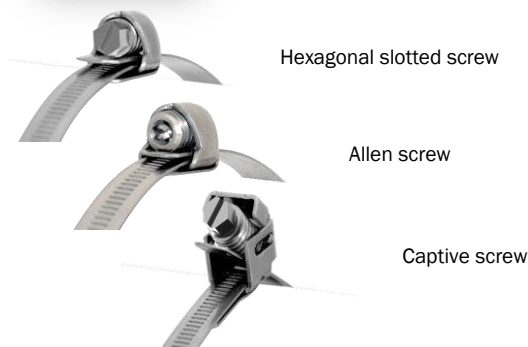

Corrosion Resistance: 1000 hours NSS Test

Fastening: 7mm A/F screw

Industry Recommendations:-



304 Stainless Steel

MULTIBAND 304 Slimline Stainless Steel:- 7mm Wide

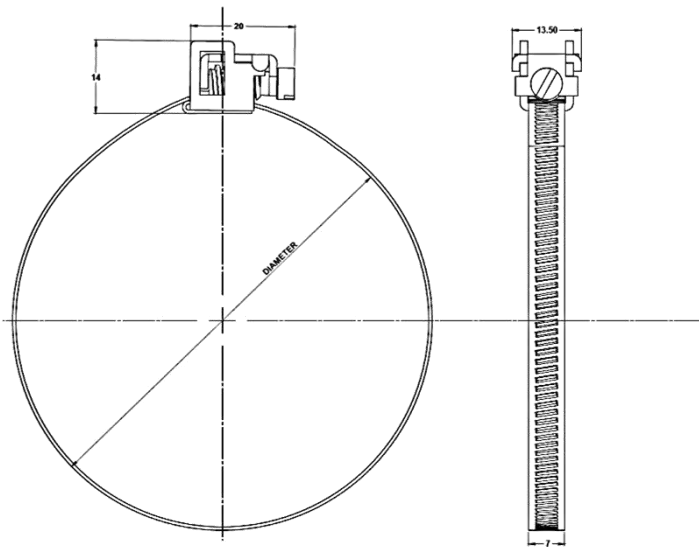
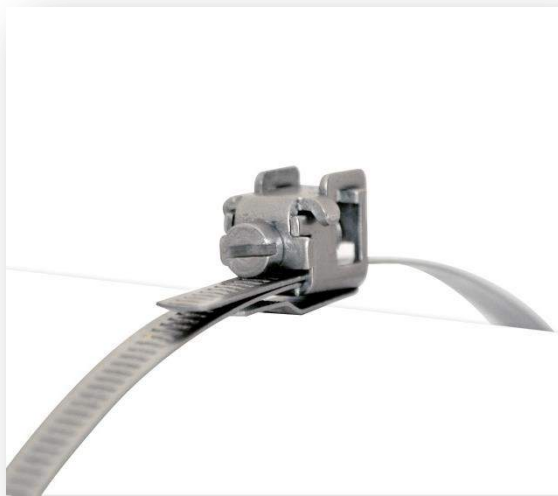

Range	Adjustment mm	Band Width mm	Band Thickness mm	Recommended Torque Nm	Maximum Torque Nm	Maximum Pressure PSI	Range
MB07SS	Cut to length	7.0	0.56	3.0	4.0	n/a	MB07SS

Component Parts for MB07SS:-



Banding in dispensers of 25 m

Part No. **MB1601**

- 7mm wide
- 25 metre roll
- 304 Stainless steel



Banding in dispensers of 50 m

Part No. **MB1602**

- 7mm wide
- 50 metre roll
- 304 Stainless steel



Flip/Lock housings/screws for use with 7mm Multiband

Part No. **MB1603 box of 25**
MB1604 box of 100

- 304 Stainless steel



Flip/lock screw

Corrosion Resistance: 1000 hours NSS Test

Fastening: 7mm A/F screw

Industry Recommendations:-



304 Stainless Steel

**The finest hose clip
in the world**



QUICK RELEASE STRAPS

Jubilee Quick Release Straps are used in a wide range of applications where a closed installation requires the clamp to be opened fully for positioning. Examples include sign fixing, cable retention, repairs and heating, ventilation and air conditioning. Jubilee Quick Release Straps are available in mild and stainless steel and manufactured at our Birmingham (UK) plant.

Jubilee Quick Release Straps are manufactured with a quick release swivel housing design which locks into position once the clip is fastened. The strong housing design ensures a higher maximum tightening torque than other quick release designs and the screw fitting requires no specialist tools to install, making installation quicker and more cost effective than some more complex solutions. The design also benefits from being reusable. Jubilee Quick Release Straps may also be used in cable retaining applications where nylon cable ties are not suitable due to fire regulations.

Jubilee Quick Release Straps have a very wide clamping range and excess band material can be removed at the point of installation. These clamps are flexible enough to conform to unusually shaped fittings and they are also suitable for very large diameter applications. Jubilee Quick Release Straps are available in 11mm band width in zinc protected mild steel and all parts 304 stainless steel. There is also a slimline 7mm band width version with flip/lock design which is available in all parts 304 stainless steel only and is suitable where space or weight are at a premium.



- 7mm hex head or slotted design
- Zinc protected mild steel or all 304 stainless steel
- 11mm or 7mm band width
- Made in UK



Available in:-

Mild Steel Zinc Protected

304 Stainless Steel

QUICK RELEASE STRAPS

Zinc Protected Mild Steel:-



Part No.	Adjustment mm	Band Width mm	Band Thickness mm	Recommended Torque Nm	Maximum Torque Nm	Part No.
CAS050MS	35-50	11	0.82	3.4	4.5	CAS050MS
CAS075MS	45-75	11	0.82	3.4	4.5	CAS075MS
CAS100MS	50-100	11	0.82	3.4	4.5	CAS100MS
CAS120MS	50-120	11	0.82	3.4	4.5	CAS120MS
CAS150MS	50-150	11	0.82	3.4	4.5	CAS150MS
CAS175MS	50-175	11	0.82	3.4	4.5	CAS175MS
CAS200MS	50-200	11	0.82	3.4	4.5	CAS200MS
CAS225MS	50-225	11	0.82	3.4	4.5	CAS225MS
CAS250MS	50-250	11	0.82	3.4	4.5	CAS250MS
CAS275MS	50-275	11	0.82	3.4	4.5	CAS275MS
CAS300MS	50-300	11	0.82	3.4	4.5	CAS300MS
CAS330MS	50-330	11	0.82	3.4	4.5	CAS330MS
CAS355MS	50-355	11	0.82	3.4	4.5	CAS355MS
CAS380MS	50-380	11	0.82	3.4	4.5	CAS380MS
CAS405MS	50-405	11	0.82	3.4	4.5	CAS405MS
CAS455MS	50-455	11	0.82	3.4	4.5	CAS455MS
CAS505MS	50-505	11	0.82	3.4	4.5	CAS505MS
CAS555MS	50-555	11	0.82	3.4	4.5	CAS555MS
CAS605MS	50-605	11	0.82	3.4	4.5	CAS605MS
CAS710MS	50-710	11	0.82	3.4	4.5	CAS710MS
CAS810MS	50-810	11	0.82	3.4	4.5	CAS810MS
CAS910MS	50-910	11	0.82	3.4	4.5	CAS910MS
CAS965MS	50-965	11	0.82	3.4	4.5	CAS965MS

Corrosion Resistance: 240 hours NSS Test

Fastening: 7mm A/F (captive housing and screw)

Industry Recommendations:-



Mild Steel Zinc Protected

The finest hose clip
in the world



QUICK RELEASE STRAPS

304 Stainless Steel:-

11mm Wide

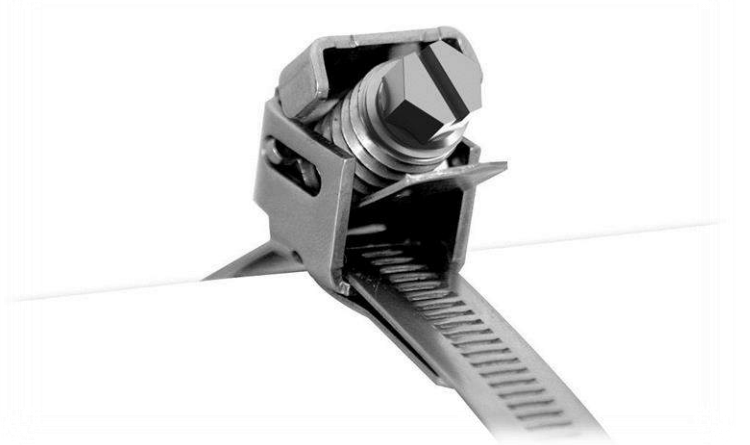

Part No.	Adjustment mm	Band Width mm	Band Thickness mm	Recommended Torque Nm	Maximum Torque Nm	Part No.
CAS050SS	35-50	11	0.80	3.4	4.5	CAS050SS
CAS075SS	45-75	11	0.80	3.4	4.5	CAS075SS
CAS100SS	50-100	11	0.80	3.4	4.5	CAS100SS
CAS120SS	50-120	11	0.80	3.4	4.5	CAS120SS
CAS150SS	50-150	11	0.80	3.4	4.5	CAS150SS
CAS175SS	50-175	11	0.80	3.4	4.5	CAS175SS
CAS200SS	50-200	11	0.80	3.4	4.5	CAS200SS
CAS225SS	50-225	11	0.80	3.4	4.5	CAS225SS
CAS250SS	50-250	11	0.80	3.4	4.5	CAS250SS
CAS275SS	50-275	11	0.80	3.4	4.5	CAS275SS
CAS300SS	50-300	11	0.80	3.4	4.5	CAS300SS
CAS330SS	50-330	11	0.80	3.4	4.5	CAS330SS
CAS355SS	50-355	11	0.80	3.4	4.5	CAS355SS
CAS380SS	50-380	11	0.80	3.4	4.5	CAS380SS
CAS405SS	50-405	11	0.80	3.4	4.5	CAS405SS
CAS455SS	50-455	11	0.80	3.4	4.5	CAS455SS
CAS505SS	50-505	11	0.80	3.4	4.5	CAS505SS
CAS555SS	50-555	11	0.80	3.4	4.5	CAS555SS
CAS605SS	50-605	11	0.80	3.4	4.5	CAS605SS
CAS710SS	50-710	11	0.80	3.4	4.5	CAS710SS
CAS810SS	50-810	11	0.80	3.4	4.5	CAS810SS
CAS910SS	50-910	11	0.80	3.4	4.5	CAS910SS
CAS965SS	50-965	11	0.80	3.4	4.5	CAS965SS

Corrosion Resistance: 1000 hours NSS Test

Fastening: 7mm A/F (captive housing and screw)

Industry Recommendations:-



304 Stainless Steel

QUICK RELEASE STRAPS

304 Stainless Steel:-

7mm Wide



Part No.	Adjustment mm	Band Width mm	Band Thickness mm	Recommended Torque Nm	Maximum Torque Nm	Part No.
FLS050SS	35-50	7	0.56	3.0	4.0	FLS050SS
FLS075SS	45-75	7	0.56	3.0	4.0	FLS075SS
FLS100SS	50-100	7	0.56	3.0	4.0	FLS100SS
FLS120SS	50-120	7	0.56	3.0	4.0	FLS120SS
FLS150SS	50-150	7	0.56	3.0	4.0	FLS150SS
FLS175SS	50-175	7	0.56	3.0	4.0	FLS175SS
FLS200SS	50-200	7	0.56	3.0	4.0	FLS200SS
FLS225SS	50-225	7	0.56	3.0	4.0	FLS225SS
FLS225SS	50-250	7	0.56	3.0	4.0	FLS225SS
FLS275SS	50-275	7	0.56	3.0	4.0	FLS275SS
FLS300SS	50-300	7	0.56	3.0	4.0	FLS300SS
FLS330SS	50-330	7	0.56	3.0	4.0	FLS330SS
FLS355SS	50-355	7	0.56	3.0	4.0	FLS355SS
FLS380SS	50-380	7	0.56	3.0	4.0	FLS380SS
FLS405SS	50-405	7	0.56	3.0	4.0	FLS405SS



Corrosion Resistance: 1000 hours NSS Test

Fastening: 7mm A/F (flip/lock housing and screw)

Industry Recommendations:-



304 Stainless Steel

The finest hose clip
in the world



SUPERCLAMPS

Jubilee® Superclamps are manufactured in mild steel zinc plated, all 304 stainless steel and all 316 stainless steel and the latter are predominantly suited for applications where high corrosion resistance is required. These powerful clamps are ideal for marine and offshore oil and gas applications, as well as the food and chemicals industries.



These clamps can also be used in place of SAE J1508 type TB or T-Bolt style clamps.

Available from size 17mm, with size 64mm and above offering the highest tightening torques with 8.8 high tensile bolts allowing an impressive maximum recommended torque of 25 Nm. Naturally with the smaller clamps using a smaller bolt the torques are lower, but even so, the torques are impressive by comparison to alternatives for the same size range.

Superclamps are particularly suited for delivery and suction hoses requiring a very tight seal and agricultural applications, waste water extraction, mining, quarrying or on other sectors where a heavy-duty clamp is required.

- Single nut adjustment
- Smooth band protects hose
- Bridge piece ensures 360° seal
- Solid trunion maximises torque
- Assembly by manual or automatic tools
- Chromium VI free finish on all materials

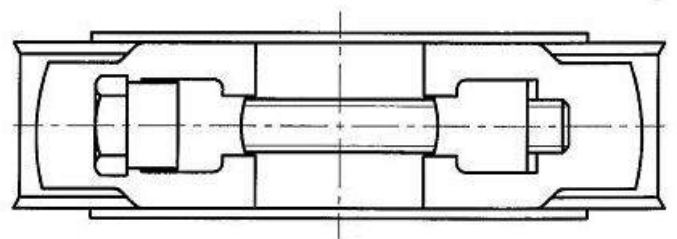

Available in:-

Mild Steel Zinc Plated

304 Stainless Steel

316 Stainless Steel

SUPERCLAMPS

Mild Steel Zinc Plated:-

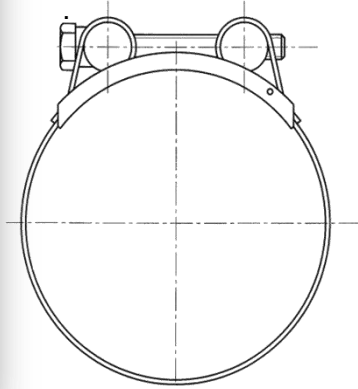

Part No.	Adjustment mm	Band Width mm	Band Thickness mm	Recommended Torque Nm	Maximum Torque Nm	Screw Head mm	Part No.
JSC019MS	17-19	18.0	0.6	4.5	6.0	8	JSC019MS
JSC022MS	20-22	18.0	0.6	4.5	6.0	8	JSC022MS
JSC025MS	23-25	18.0	0.6	4.5	6.0	8	JSC025MS
JSC028MS	26-28	18.0	0.6	4.5	6.0	8	JSC028MS
JSC031MS	29-31	18.0	0.6	4.5	6.0	8	JSC031MS
JSC035MS	32-35	20.0	1.0	6	8.0	10	JSC035MS
JSC039MS	36-39	20.0	1.0	6	8.0	10	JSC039MS
JSC043MS	40-43	20.0	1.0	6	8.0	10	JSC043MS
JSC047MS	44-47	20.0	1.0	6	8.0	10	JSC047MS
JSC051MS	48-51	20.0	1.0	6	8.0	10	JSC051MS
JSC055MS	52-55	20.0	1.0	6	8.0	10	JSC055MS
JSC059MS	56-59	20.0	1.0	6	8.0	10	JSC059MS
JSC063MS	60-63	20.0	1.0	6	8.0	10	JSC063MS
JSC067MS	64-67	25.0	1.5	18.5	25.0	13	JSC067MS
JSC073MS	68-73	25.0	1.5	18.5	25.0	13	JSC073MS
JSC079MS	74-79	25.0	1.5	18.5	25.0	13	JSC079MS
JSC085MS	80-85	25.0	1.5	18.5	25.0	13	JSC085MS
JSC091MS	86-91	25.0	1.5	18.5	25.0	13	JSC091MS
JSC097MS	92-97	25.0	1.5	18.5	25.0	13	JSC097MS
JSC103MS	98-103	25.0	1.5	18.5	25.0	13	JSC103MS
JSC112MS	104-112	25.0	1.5	18.5	25.0	13	JSC112MS
JSC121MS	113-121	25.0	1.5	18.5	25.0	13	JSC121MS
JSC130MS	122-130	25.0	1.5	18.5	25.0	13	JSC130MS
JSC139MS	131-139	25.0	1.5	18.5	25.0	13	JSC139MS
JSC148MS	140-148	25.0	1.8	18.5	25.0	13	JSC148MS
JSC161MS	149-161	25.0	1.8	18.5	25.0	13	JSC161MS
JSC174MS	162-174	25.0	1.8	18.5	25.0	13	JSC174MS
JSC187MS	175-187	25.0	1.8	18.5	25.0	13	JSC187MS
JSC200MS	188-200	25.0	1.8	18.5	25.0	13	JSC200MS
JSC213MS	201-213	25.0	1.8	18.5	25.0	13	JSC213MS
JSC226MS	214-226	25.0	1.8	18.5	25.0	13	JSC226MS
JSC239MS	227-239	25.0	1.8	18.5	25.0	13	JSC239MS
JSC252MS	240-252	25.0	1.8	18.5	25.0	13	JSC252MS
JSC265MS	253-265	25.0	1.8	18.5	25.0	13	JSC265MS

Corrosion Resistance: 168 hours NSS Test

Fastening: A/F screw – see table

Industry Recommendations:-



Quality Assurance:-



Mild Steel Zinc Plated

The finest hose clip
in the world



SUPERCLAMPS 304 Stainless Steel:-

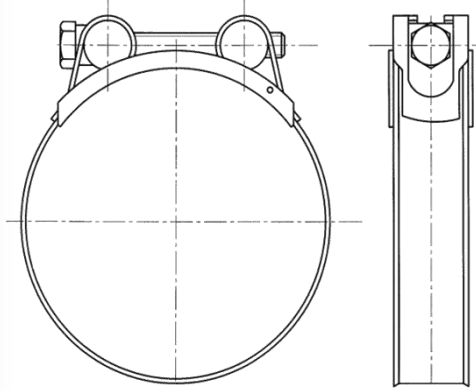

Part No.	Adjustment mm	Band Width mm	Band Thickness mm	Recommended Torque Nm	Maximum Torque Nm	Screw Head mm	Part No.
JSC019SS	17-19	18.0	0.6	4.5	6.0	8	JSC019SS
JSC022SS	20-22	18.0	0.6	4.5	6.0	8	JSC022SS
JSC025SS	23-25	18.0	0.6	4.5	6.0	8	JSC025SS
JSC028SS	26-28	18.0	0.6	4.5	6.0	8	JSC028SS
JSC031SS	29-31	18.0	0.6	4.5	6.0	8	JSC031SS
JSC035SS	32-35	20.0	1.0	6	8.0	10	JSC035SS
JSC039SS	36-39	20.0	1.0	6	8.0	10	JSC039SS
JSC043SS	40-43	20.0	1.0	6	8.0	10	JSC043SS
JSC047SS	44-47	20.0	1.0	6	8.0	10	JSC047SS
JSC051SS	48-51	20.0	1.0	6	8.0	10	JSC051SS
JSC055SS	52-55	20.0	1.0	6	8.0	10	JSC055SS
JSC059SS	56-59	20.0	1.0	6	8.0	10	JSC059SS
JSC063SS	60-63	20.0	1.0	6	8.0	10	JSC063SS
JSC067SS	64-67	25.0	1.5	18.5	25.0	13	JSC067SS
JSC073SS	68-73	25.0	1.5	18.5	25.0	13	JSC073SS
JSC079SS	74-79	25.0	1.5	18.5	25.0	13	JSC079SS
JSC085SS	80-85	25.0	1.5	18.5	25.0	13	JSC085SS
JSC091SS	86-91	25.0	1.5	18.5	25.0	13	JSC091SS
JSC097SS	92-97	25.0	1.5	18.5	25.0	13	JSC097SS
JSC103SS	98-103	25.0	1.5	18.5	25.0	13	JSC103SS
JSC112SS	104-112	25.0	1.5	18.5	25.0	13	JSC112SS
JSC121SS	113-121	25.0	1.5	18.5	25.0	13	JSC121SS
JSC130SS	122-130	25.0	1.5	18.5	25.0	13	JSC130SS
JSC139SS	131-139	25.0	1.5	18.5	25.0	13	JSC139SS
JSC148SS	140-148	25.0	1.8	18.5	25.0	13	JSC148SS
JSC161SS	149-161	25.0	1.8	18.5	25.0	13	JSC161SS
JSC174SS	162-174	25.0	1.8	18.5	25.0	13	JSC174SS
JSC187SS	175-187	25.0	1.8	18.5	25.0	13	JSC187SS
JSC200SS	188-200	25.0	1.8	18.5	25.0	13	JSC200SS
JSC213SS	201-213	25.0	1.8	18.5	25.0	13	JSC213SS
JSC226SS	214-226	25.0	1.8	18.5	25.0	13	JSC226SS
JSC239SS	227-239	25.0	1.8	18.5	25.0	13	JSC239SS
JSC252SS	240-252	25.0	1.8	18.5	25.0	13	JSC252SS
JSC265SS	253-265	25.0	1.8	18.5	25.0	13	JSC265SS

Corrosion Resistance: 1000 hours NSS Test

Fastening: A/F screw – see table

Industry Recommendations:-



Quality Assurance:-



304 Stainless Steel

SUPERCLAMPS

316 Stainless Steel (HNSS):-

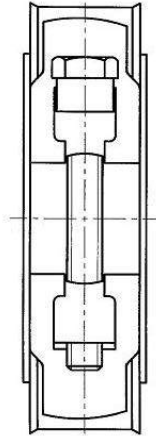

Part No.	Adjustment mm	Band Width mm	Band Thickness mm	Recommended Torque Nm	Maximum Torque Nm	Screw Head mm	Part No.
JSC019SS316	17-19	18.0	0.6	4.5	6.0	8	JSC019SS316
JSC022SS316	20-22	18.0	0.6	4.5	6.0	8	JSC022SS316
JSC025SS316	23-25	18.0	0.6	4.5	6.0	8	JSC025SS316
JSC028SS316	26-28	18.0	0.6	4.5	6.0	8	JSC028SS316
JSC031SS316	29-31	18.0	0.6	4.5	6.0	8	JSC031SS316
JSC035SS316	32-35	20.0	1.0	6	8.0	10	JSC035SS316
JSC039SS316	36-39	20.0	1.0	6	8.0	10	JSC039SS316
JSC043SS316	40-43	20.0	1.0	6	8.0	10	JSC043SS316
JSC047SS316	44-47	20.0	1.0	6	8.0	10	JSC047SS316
JSC051SS316	48-51	20.0	1.0	6	8.0	10	JSC051SS316
JSC055SS316	52-55	20.0	1.0	6	8.0	10	JSC055SS316
JSC059SS316	56-59	20.0	1.0	6	8.0	10	JSC059SS316
JSC063SS316	60-63	20.0	1.0	6	8.0	10	JSC063SS316
JSC067SS316	64-67	25.0	1.5	18.5	25.0	13	JSC067SS316
JSC073SS316	68-73	25.0	1.5	18.5	25.0	13	JSC073SS316
JSC079SS316	74-79	25.0	1.5	18.5	25.0	13	JSC079SS316
JSC085SS316	80-85	25.0	1.5	18.5	25.0	13	JSC085SS316
JSC091SS316	86-91	25.0	1.5	18.5	25.0	13	JSC091SS316
JSC097SS316	92-97	25.0	1.5	18.5	25.0	13	JSC097SS316
JSC103SS316	98-103	25.0	1.5	18.5	25.0	13	JSC103SS316
JSC112SS316	104-112	25.0	1.5	18.5	25.0	13	JSC112SS316
JSC121SS316	113-121	25.0	1.5	18.5	25.0	13	JSC121SS316
JSC130SS316	122-130	25.0	1.5	18.5	25.0	13	JSC130SS316
JSC139SS316	131-139	25.0	1.5	18.5	25.0	13	JSC139SS316
JSC148SS316	140-148	25.0	1.8	18.5	25.0	13	JSC148SS316
JSC161SS316	149-161	25.0	1.8	18.5	25.0	13	JSC161SS316
JSC174SS316	162-174	25.0	1.8	18.5	25.0	13	JSC174SS316
JSC187SS316	175-187	25.0	1.8	18.5	25.0	13	JSC187SS316
JSC200SS316	188-200	25.0	1.8	18.5	25.0	13	JSC200SS316
JSC213SS316	201-213	25.0	1.8	18.5	25.0	13	JSC213SS316
JSC226SS316	214-226	25.0	1.8	18.5	25.0	13	JSC226SS316
JSC239SS316	227-239	25.0	1.8	18.5	25.0	13	JSC239SS316
JSC252SS316	240-252	25.0	1.8	18.5	25.0	13	JSC252SS316
JSC265SS316	253-265	25.0	1.8	18.5	25.0	13	JSC265SS316

Corrosion Resistance: 2000 hours NSS Test

Fastening: A/F screw – see table

Industry Recommendations:-



Quality Assurance:-



316 Stainless Steel

The finest hose clip
in the world



LIGHT RANGE

With a narrower band than the Original Jubilee® Clip, this lightweight clip is designed to offer an excellent seal at slightly lower torques. The Jubilee® Light Range is manufactured to DIN 3017 and, like the Original Jubilee® Clip, all clips are continuously threaded to enable extra flexibility when adjusting the clips to the required size. This clip is most suited to applications where space, or weight, is restricted and often used in car and light commercial vehicle applications.



The Jubilee® Light Range clip meets the high standard of quality and performance required of all Jubilee® products. The benefits of weight saving and extra corrosion resistance allow this addition to the full range of Jubilee clips to offer the customer a greater flexibility in meeting their own requirements.

Our Jubilee® Light Range in zinc protected mild steel was originally designed specifically for use in the automotive industry and the automotive aftermarket to comply with DIN 3017, but are also suited for other applications where space, or weight, is restricted in e.g. agricultural applications, the industrial sector and hardware/DIY applications.

Jubilee® Light Range hose clips in 304 (18/8) stainless steel are used in the marine, oil and gas and food sectors, as well as the agricultural, hardware and industrial sectors, where higher corrosion resistance is required, but space and/or weight are at a premium.

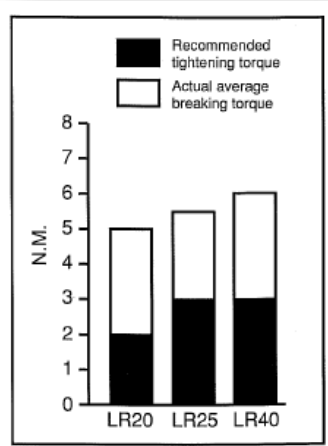

Available in:-

Mild Steel Zinc Protected

304 Stainless Steel

LIGHT RANGE

Mild Steel Zinc Protected:-

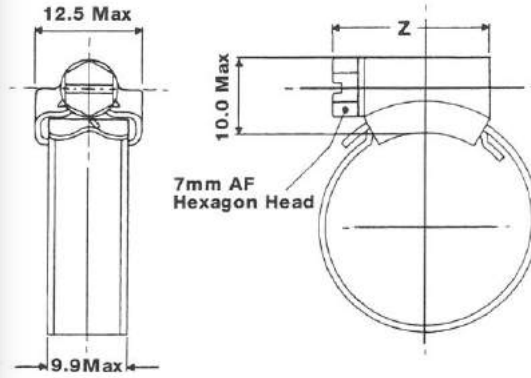

Part No.	Adjustment mm	Band Width mm	Band Thickness mm	Recommended Torque Nm	Maximum Torque Nm	Maximum Pressure Psi	Part No.
000MS	9.5-12	9.9	0.762	3.4	4.5	203	000MS
M00MS	11-16	9.9	0.762	3.4	4.5	203	M00MS
00MS	13-20	9.9	0.762	3.4	4.5	203	00MS
LR022MS	12-22	9.9	0.762	3.4	4.5	182	LR022MS
LR027MS	16-27	9.9	0.762	3.4	4.5	182	LR027MS
LR032MS	20-32	9.9	0.762	3.4	4.5	92	LR032MS
LR040MS	25-40	9.9	0.762	4.5	6.0	92	LR040MS
LR045MS	30-45	9.9	0.762	4.5	6.0	92	LR045MS
LR050MS	32-50	9.9	0.762	4.5	6.0	92	LR050MS
LR060MS	40-60	9.9	0.762	4.5	6.0	92	LR060MS
LR070MS	50-70	9.9	0.762	4.5	6.0	92	LR070MS
LR080MS	60-80	9.9	0.762	4.5	6.0	39	LR080MS
LR090MS	70-90	9.9	0.762	4.5	6.0	39	LR090MS
LR100MS	80-100	9.9	0.762	4.5	6.0	39	LR100MS
LR110MS	90-110	9.9	0.762	4.5	6.0	39	LR110MS
LR120MS	100-120	9.9	0.762	4.5	6.0	39	LR120MS
LR130MS	110-130	9.9	0.762	4.5	6.0	39	LR130MS
LR140MS	120-140	9.9	0.762	4.5	6.0	39	LR140MS
LR150MS	130-150	9.9	0.762	4.5	6.0	17	LR150MS
LR160MS	140-160	9.9	0.762	4.5	6.0	17	LR160MS

Corrosion Resistance: 240 hours NSS Test

Fastening: 7mm A/F screw

Industry Recommendations:-

Quality Assurance:-



Mild Steel Zinc Protected

The finest hose clip
in the world



LIGHT RANGE 304 Stainless Steel:-



Part No.	Adjustment mm	Band Width mm	Band Thickness mm	Recommended Torque Nm	Maximum Torque Nm	Maximum Pressure Psi	Part No.
000SS	9.5-12	9.9	0.762	3.4	4.5	203	000SS
M00SS	11-16	9.9	0.762	3.4	4.5	203	M00SS
O0SS	13-20	9.9	0.762	3.4	4.5	203	O0SS
LR022SS	12-22	9.9	0.762	3.4	4.5	182	LR022SS
LR027SS	16-27	9.9	0.762	3.4	4.5	182	LR027SS
LR032SS	20-32	9.9	0.762	3.4	4.5	92	LR032SS
LR040SS	25-40	9.9	0.762	4.5	6.0	92	LR040SS
LR045SS	30-45	9.9	0.762	4.5	6.0	92	LR045SS
LR050SS	32-50	9.9	0.762	4.5	6.0	92	LR050SS
LR060SS	40-60	9.9	0.762	4.5	6.0	92	LR060SS
LR070SS	50-70	9.9	0.762	4.5	6.0	92	LR070SS
LR080SS	60-80	9.9	0.762	4.5	6.0	39	LR080SS
LR090SS	70-90	9.9	0.762	4.5	6.0	39	LR090SS
LR100SS	80-100	9.9	0.762	4.5	6.0	39	LR100SS
LR110SS	90-110	9.9	0.762	4.5	6.0	39	LR110SS
LR120SS	100-120	9.9	0.762	4.5	6.0	39	LR120SS
LR130SS	110-130	9.9	0.762	4.5	6.0	39	LR130SS
LR140SS	120-140	9.9	0.762	4.5	6.0	39	LR140SS
LR150SS	130-150	9.9	0.762	4.5	6.0	17	LR150SS
LR160SS	140-160	9.9	0.762	4.5	6.0	17	LR160SS

Corrosion Resistance: 1000 hours NSS Test

Fastening: 7mm A/F screw

Industry Recommendations:-

Quality Assurance:-



DIN
3017

SAE
INTERNATIONAL
FE



304 Stainless Steel

WINGSPADE



Based on Jubilee® Light Range Clips and suitable for hand fitting; Jubilee Wingspade® clips are supplied with a thumb screw, allowing easy torquing using just a thumb and forefinger. Suitable for applications where there is a requirement for frequent tightening/loosening on low torque applications; mainly for the hardware market.

This product range is manufactured to DIN Standard and has a plastic spade for ease of use. Wingspades are suited to fittings that may need to be removed from time to time such as dust extraction units, garden hoses and other domestic applications. The range starts from 9.5mm and extends through to 70mm. Wingspades are available in zinc protected mild steel only.

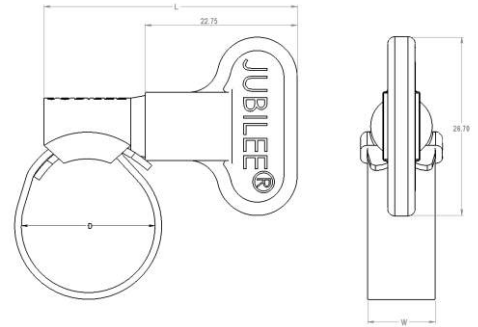

Part No.	Adjustment mm	Band Width mm	Band Thickness mm	Recommended Torque Nm	Maximum Torque Nm	Maximum Pressure PSI	Part No.
WS012MS	9.5-12	9.9	0.762	3.4	4.5	182	WS012MS
WS016MS	11-16	9.9	0.762	3.4	4.5	182	WS016MS
WS020MS	13-20	9.9	0.762	3.4	4.5	182	WS020MS
WS022MS	12-22	9.9	0.762	3.4	4.5	182	WS022MS
WS027MS	16-27	9.9	0.762	3.4	4.5	182	WS027MS
WS032MS	20-32	9.9	0.762	3.4	4.5	92	WS032MS
WS040MS	25-40	9.9	0.762	4.5	6.0	92	WS040MS
WS045MS	30-45	9.9	0.762	4.5	6.0	92	WS045MS



Corrosion Resistance: 240 hours NSS Test

Fastening: Wing screw

Industry Recommendations:-

Quality Assurance:-



Mild Steel Zinc Protected

The finest hose clip
in the world



JUBILEE® P CLIPS

Jubilee® P Clips are suitable for retaining pipes, cables and hoses.



Jubilee® P Clips are manufactured from a flexible steel or stainless steel one piece band with an ethylene-propylene-diene monomer (EPDM) rubber liner. The band features a stepped design to allow the clip to sit flush with the rubber liner in place. The single piece construction means that there are no joins which makes the clip very strong. The upper hole has an elongated design allowing easy fitting of the clip. The rubber liner is manufactured in a corresponding profile to be secure in its position on the clip and ensures a tight fit as well as vibration damping and sound insulation. EPDM rubber offers several advantages over alternatives such as, a wide operating temperature range, resistance to UV (ultra violet) weathering and resistance to creep.

Jubilee® P Clips are available in all of the most important standard sizes. Special production of other sizes or using different lining materials may be available on request for large order volumes.

- Operating temperature range -50°C to 150°C
- Good UV weathering resistance
- Offers good resistance to creep
- Delivers good abrasion resistance
- Advanced resistance to ozone
- Highly developed resistance to ageing
- Halogen Free
- Reinforced step not required



(Fixing not supplied)

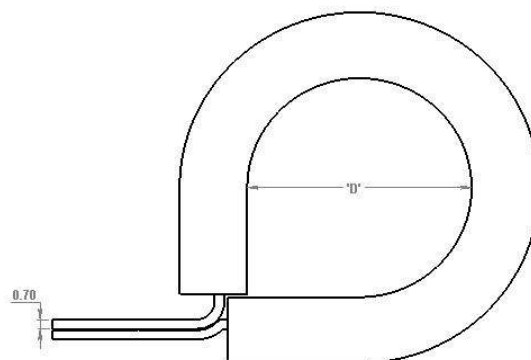
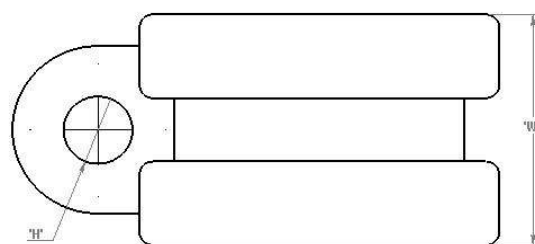

Available in:-

Mild Steel Zinc Plated

304 Stainless Steel

P CLIPS

Mild Steel Zinc Plated:-

Part No.	Diameter (mm)		Band Width mm	Fastening	Part No.
	Min.	Max.			
JPC005MS	4.5	6	12.7	M4/5	JPC005MS
JPC006MS	5.5	8	12.7	M4/5	JPC006MS
JPC008MS	7.5	10	12.7	M4/5	JPC008MS
JPC009MS	8.5	11	12.7	M4/5	JPC009MS
JPC010MS	9.5	12	12.7	M4/5	JPC010MS
JPC012MS	11.5	14	12.7	M4/5	JPC012MS
JPC013MS	12.5	15	12.7	M4/5	JPC013MS
JPC014MS	13.5	16	12.7	M4/5	JPC014MS
JPC015MS	14.5	17	12.7	M4/5	JPC015MS
JPC016MS	15.5	18	12.7	M4/5	JPC016MS
JPC017MS	16.5	19	12.7	M4/5	JPC017MS
JPC018MS	17.5	20	12.7	M4/5	JPC018MS
JPC019MS	18.5	21	12.7	M4/5	JPC019MS
JPC020MS	19.5	22	12.7	M4/5	JPC020MS
JPC021MS	20.5	23	12.7	M4/5	JPC021MS
JPC022MS	21.5	24	12.7	M4/5	JPC022MS
JPC025MS	24.5	27	12.7	M4/5	JPC025MS
JPC027MS	26.5	29	12.7	M4/5	JPC027MS
JPC028MS	27.5	30	12.7	M4/5	JPC028MS
JPC029MS	28.5	31	12.7	M4/5	JPC029MS
JPC030MS	29.5	32	12.7	M4/5	JPC030MS
JPC035MS	34.5	37	12.7	M4/5	JPC035MS
JPC040MS	39.5	42	12.7	M4/5	JPC040MS
JPC044MS	43.5	46	12.7	M4/5	JPC044MS

Corrosion Resistance: 72 hours NSS Test

Fastening: See table

Industry Recommendations:-

Quality Assurance:-



Mild Steel Zinc Plated



P CLIPS

304 Stainless Steel:-

Part No.	Diameter (mm)		Band Width mm	Fastening	Part No.
	Min.	Max.			
JPC005SS	4.5	6	12.7	M6	JPC005SS
JPC006SS	5.5	8	12.7	M6	JPC006SS
JPC008SS	7.5	10	12.7	M6	JPC008SS
JPC009SS	8.5	11	12.7	M6	JPC009SS
JPC010SS	9.5	12	12.7	M6	JPC010SS
JPC012SS	11.5	14	12.7	M6	JPC012SS
JPC013SS	12.5	15	12.7	M6	JPC013SS
JPC014SS	13.5	16	12.7	M6	JPC014SS
JPC015SS	14.5	17	12.7	M6	JPC015SS
JPC016SS	15.5	18	12.7	M6	JPC016SS
JPC017SS	16.5	19	12.7	M6	JPC017SS
JPC018SS	17.5	20	12.7	M6	JPC018SS
JPC019SS	18.5	21	12.7	M6	JPC019SS
JPC020SS	19.5	22	12.7	M6	JPC020SS
JPC021SS	20.5	23	12.7	M6	JPC021SS
JPC022SS	21.5	24	12.7	M6	JPC022SS
JPC025SS	24.5	27	12.7	M6	JPC025SS
JPC027SS	26.5	29	12.7	M6	JPC027SS
JPC028SS	27.5	30	12.7	M6	JPC028SS
JPC029SS	28.5	31	12.7	M6	JPC029SS
JPC030SS	29.5	32	12.7	M6	JPC030SS
JPC035SS	34.5	37	12.7	M6	JPC035SS
JPC040SS	39.5	42	12.7	M6	JPC040SS
JPC044SS	43.5	46	12.7	M6	JPC044SS

Corrosion Resistance: 1000 hours NSS Test

Fastening: See table

Industry Recommendations:-

Quality Assurance:-



304 Stainless Steel



The finest hose clip in the world



'O' CLIPS FROM JUBILEE®

Jubilee 'O' Clip 2-Ear clamps are widely used for maintenance and OEM applications. Mainly used on air, fluid, gas and steam lines and also suitable for low pressure hydraulic applications.

The absence of a screw mechanism allows Jubilee® 'O' Clips to be useful on extremely small hoses. The tamper proof nature of the fitting may also make the Jubilee® 'O' Clips suitable for certain applications where there may be a risk associated with any interference to the fitting. Sometimes affectionately referred to as "Lemon Clips" due to their shape and also referred to as double ear clips and 2-ear clips.

Pincers (both normal closing and side closing) are used to crimp the ears of the clamps and affect a proper seal.

2-ear clamps are best installed by closing one ear fully first, the second ear is then closed so that the first ear opens slightly (gap to be approximately 1.5mm). This builds a resilient strength into the clamp in a spring-like action to hold against pressure, vibration and hose shrinkage due to temperature changes or ageing.

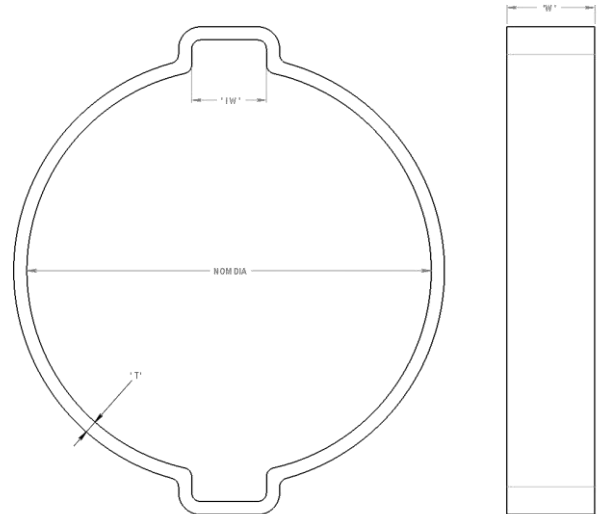
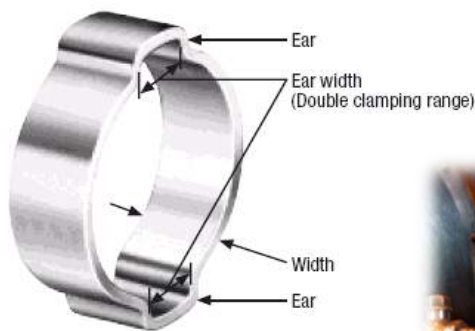

Normal Closing & Side Closing Pincer



Position clip on hose, crimp one ear fully first before firmly squeezing the other ear.

Use side closing pincers where access to ear is difficult.



To remove a clamp, place the pincer jaws across the ear and cut through it.

Available in:-

Mild Steel Zinc Plated

304 Stainless Steel

'O' CLIPS

Mild Steel Zinc Plated:-

Part No.	Adjustment mm	Band Width mm	Band Thickness mm	Maximum Pressure PSI	Part No.
OC0305MS	3-5	5.0	0.7	200	OC0305MS
OC0507MS	5-7	6.0	0.7	200	OC0507MS
OC0709MS	7-9	7.0	1.0	200	OC0709MS
OC0811MS	8-11	7.0	1.0	200	OC0811MS
OC0911MS	9-11	7.0	1.0	200	OC0911MS
OC1113MS	11-13	7.0	1.0	200	OC1113MS
OC1315MS	13-15	7.5	1.0	200	OC1315MS
OC1517MS	15-17	8.0	1.2	200	OC1517MS
OC1518MS	15-18	8.0	1.2	200	OC1518MS
OC1619MS	16-19	8.0	1.2	200	OC1619MS
OC1720MS	17-20	8.5	1.2	200	OC1720MS
OC1922MS	19-22	9.0	1.5	180	OC1922MS
OC2023MS	20-23	9.0	1.5	180	OC2023MS
OC2225MS	22-25	10.0	1.5	180	OC2225MS
OC2327MS	23-27	10.0	1.5	180	OC2327MS
OC2528MS	25-28	10.0	1.5	180	OC2528MS
OC2731MS	27-31	10.0	1.5	180	OC2731MS
OC2831MS	28-31	10.0	1.5	180	OC2831MS
OC3134MS	31-34	10.0	1.5	75	OC3134MS
OC3437MS	34-37	10.0	1.5	75	OC3437MS
OC3740MS	37-40	10.0	1.5	75	OC3740MS
OC4043MS	40-43	10.0	1.5	75	OC4043MS
OC4346MS	43-46	10.0	1.5	75	OC4346MS

Corrosion Resistance: 72 hours NSS Test

Fastening: Pinch

Industry Recommendations:-

Quality Assurance:-



Mild Steel Zinc Plated



'O' CLIPS

304 Stainless Steel:-

Part No.	Adjustment mm	Band Width mm	Band Thickness mm	Maximum Pressure Psi	Part No.
OC0305SS	3-5	5.0	0.7	200	OC0305SS
OC0507SS	5-7	6.0	0.7	200	OC0507SS
OC0709SS	7-9	7.0	1.0	200	OC0709SS
OC0911SS	9-11	7.0	1.0	200	OC0911SS
OC1113SS	11-13	7.0	1.0	200	OC1113SS
OC1315SS	13-15	7.5	1.0	200	OC1315SS
OC1517SS	15-17	8.0	1.2	200	OC1517SS
OC1518SS	15-18	8.0	1.2	200	OC1518SS
OC1720SS	17-20	8.5	1.2	200	OC1720SS
OC1922SS	19-22	9.0	1.5	180	OC1922SS
OC2023SS	20-23	9.0	1.5	180	OC2023SS
OC2225SS	22-25	10.0	1.5	180	OC2225SS
OC2327SS	23-27	10.0	1.5	180	OC2327SS
OC2528SS	25-28	10.0	1.5	180	OC2528SS
OC2731SS	27-31	10.0	1.5	180	OC2731SS
OC2831SS	28-31	10.0	1.5	180	OC2831SS
OC3134SS	31-34	10.0	1.5	75	OC3134SS
OC3437SS	34-37	10.0	1.5	75	OC3437SS
OC3740SS	37-40	10.0	1.5	75	OC3740SS
OC4043SS	40-43	10.0	1.5	75	OC4043SS
OC4346SS	43-46	10.0	1.5	75	OC4346SS

Corrosion Resistance: 1000 hours NSS Test

Fastening: Pinch

Industry Recommendations:-

Quality Assurance:-



304 Stainless Steel



The finest hose clip in the world



JUBILEE® JUNIOR

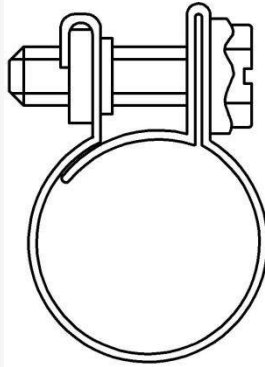

These mini clips, also known as nut & bolt clips, are ideal for small bore hoses with relatively low pressures, where little clamping force is required. Used in low pressure applications such as a fuel line.

Part No.	Adjustment mm	Band Width mm	Band Thickness mm	Recommended Torque Nm	Maximum Torque Nm	Maximum Pressure PSI	Part No.
NB0709MS	7-9	9.1	0.6	1.5	2.0	75	NB0709MS
NB0810MS	8-10	9.1	0.6	1.5	2.0	75	NB0810MS
NB0911MS	9-11	9.1	0.6	1.5	2.0	75	NB0911MS
NB1012MS	10-12	9.1	0.6	1.5	2.0	50	NB1012MS
NB1113MS	11-13	9.1	0.6	1.5	2.0	50	NB1113MS
NB1214MS	12-14	9.1	0.6	1.5	2.0	50	NB1214MS
NB1315MS	13-15	9.1	0.6	1.5	2.0	50	NB1315MS
NB1416MS	14-16	9.1	0.6	1.5	2.0	50	NB1416MS
NB1517MS	15-17	9.1	0.6	1.5	2.0	50	NB1517MS
NB1618MS	16-18	9.1	0.6	1.5	2.0	50	NB1618MS
NB1820MS	18-20	9.1	0.6	1.5	2.0	50	NB1820MS

Corrosion Resistance: 72 hours NSS Test

Fastening: 7mm A/F screw

Industry Recommendations:-

Quality Assurance:-



Mild Steel Zinc Plated

Part No.	Adjustment mm	Band Width mm	Band Thickness mm	Recommended Torque Nm	Maximum Torque Nm	Maximum Pressure PSI	Part No.
NB0709SS	7-9	9.1	0.6	1.5	2.0	75	NB0709SS
NB0810SS	8-10	9.1	0.6	1.5	2.0	75	NB0810SS
NB0911SS	9-11	9.1	0.6	1.5	2.0	75	NB0911SS
NB1012SS	10-12	9.1	0.6	1.5	2.0	50	NB1012SS
NB1113SS	11-13	9.1	0.6	1.5	2.0	50	NB1113SS
NB1214SS	12-14	9.1	0.6	1.5	2.0	50	NB1214SS
NB1315SS	13-15	9.1	0.6	1.5	2.0	50	NB1315SS
NB1416SS	14-16	9.1	0.6	1.5	2.0	50	NB1416SS

Corrosion Resistance: 1000 hours NSS Test

Fastening: 7mm A/F screw

Industry Recommendations:-

Quality Assurance:-



304 Stainless Steel

JUBILEE® CV CLIP



The Constant Velocity Boot Clip from Jubilee secures the rubber bellows to the CV joint and helps protect it from dirt and water as well as preventing lubricants from leaking.

Supplied as a flat strap, Jubilee CV Boot Clips can be easily installed by interlocking the clip hooks on the outside of the band and crimping the ear to secure. The clip must be shaped prior to assembly.

Both clip sizes have a choice of engagement positions to easily adjust to different diameters.

Essential for MOT legislation.



Part No.	Adjustment mm	Band Width mm	Band Thickness mm	Part No.
CVC050SS	25-50mm	7.0	0.8	CVC050SS
CVC110SS	40-110mm	7.0	0.8	CVC110SS
CVK015SS	Kit - see below	7.0	0.8	CVK015SS



CV Boot Clip Kit

Part No. **CVK015SS**

- 5 of size 25-50mm
- 10 of size 40-110mm
- 304 Stainless steel

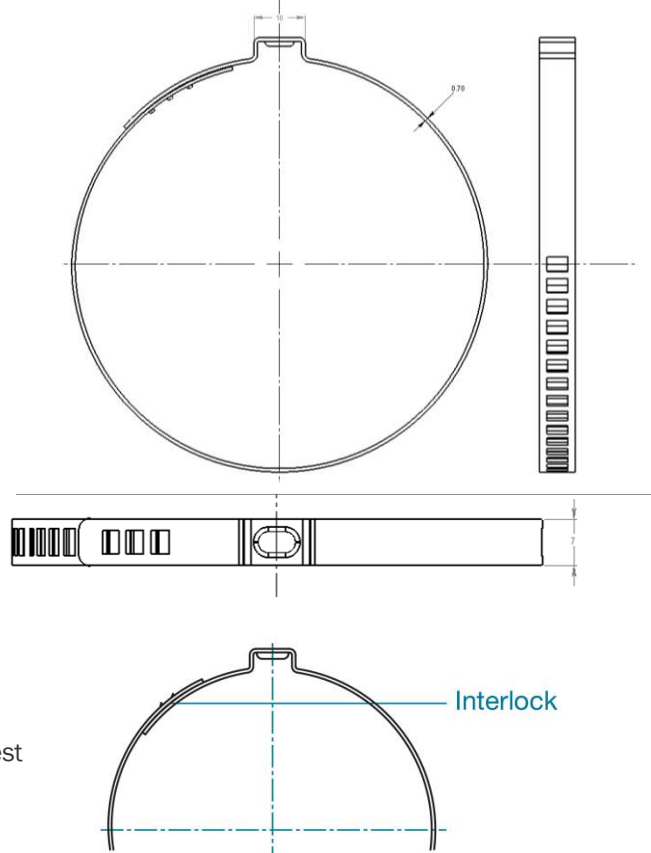

Corrosion Resistance: 1000 hours NSS Test

Fastening: Pinch

Industry Recommendations:-



Available in:-

304 Stainless Steel

**The finest hose clip
in the world**



JUBILEE® TOOLS

This carefully selected range of tools is perfectly suited to our range of products and ensures that Jubilee® Clips are not only well manufactured, but also easy to apply.



Jubilee Flexidriver®

The flexible shaft of the Jubilee Flexidriver® allows the adjustment of our clips even in difficult to reach positions. The socket is suitable to fit any 7mm across flat hexagonal headed screw.

Part No: FLX
Material: Mild Steel



Jubilee Clipdriver®

The rigid shaft Jubilee Clipdriver® for easy adjustment of Jubilee clips. Available in two lengths – 95mm and 160mm with a 7mm socket.

Part No: CDR95 = 95mm length
CDR160 = 160mm length
Material: Mild Steel



Normal Closing Pincer

Front closing pincer for crimping the ears of Jubilee® 'O' Clips or Jubilee® constant velocity (CV) boot clips.

Part No: P1098
Material: Mild Steel



Side Closing Pincer

Side closing pincer for crimping the ears of Jubilee® 'O' Clips or Jubilee® constant velocity (CV) boot clips where access to the ear is difficult.

Part No: P1099
Material: Mild Steel

JUBILEE® POINT OF SALE

Jubilee® Clip point of sale dispensers provide counter top and wall mounted displays for trade counters, as well as holding a small stock of Jubilee® products in one convenient place.



Jubilee® Clip Dispenser

The Jubilee® Clip Dispenser comes with 100 Jubilee® Clips, ten each of the most popular ten sizes of clip covering an adjustment range from 9.5mm up to 50mm and also includes three Jubilee Flexidriver® tools.

Contents: 10 of each Jubilee® Clip sizes 000, M00, 00, 0, 0X, 1A, 1, 1X, 1M & 2A plus 3 Jubilee Flexidriver®

Part No: CD100MS	Part No: CD100SS	Part No: CD100SS316
Material: Mild Steel Zinc Protected	Material: 304 Stainless Steel	Material: 316 Stainless Steel



Jubilee® Handy Pack

The Jubilee® Handy Pack includes 100 clips with ten each of the ten most popular sizes, facilitating connections from 9.5mm up to 50mm. The robust and smart cardboard outer is suitable for an end user or as a point of sale.

Contents: 10 of each Jubilee® Clip sizes 000, M00, 00, 0, 0X, 1A, 1, 1X, 1M & 2A

Part No: HP100MS	Part No: HP100SS	Part No: HP100SS316
Material: Mild Steel Zinc Protected	Material: 304 Stainless Steel	Material: 316 Stainless Steel



Jubilee® Smart Dispenser

The Jubilee® Smart Dispenser contains 540 assorted clamps displayed both loose and boxed and two Jubilee Flexidriver® tools giving an aesthetically pleasing point of sale display and a small stock holding in one single unit.

Contents: 60 of 000, M00, 00 ; 50 of 0, 0X, 1, 1X ; 40 of 1A, 1M, 2A, 2 plus 2 Jubilee Flexidriver®

Part No: SD540MS	Part No: SD540SS	Part No: SD540SS316
Material: Mild Steel Zinc Protected	Material: 304 Stainless Steel	Material: 316 Stainless Steel





L Robinson & Co (Gillingham) Limited

Owens Way, Gads Hill, Gillingham, Kent, ME7 2RS, United Kingdom.

Tel: +44 1634 281200

|

Fax: +44 1634 280101

Email: sales@jubileeclips.co.uk

|

www.jubileeclips.co.uk



Jubilee Clips Deutschland GmbH

Schottstraße 58, 56841 Trarben - Trarbach, Germany.



Tel: +49 6541 5760

|

Fax: +49 6541 3231

Email: vertrieb@jubileeclips.de

|

www.jubileeclips.de



Jubilee®, Jubilee Flexdriver®, Jubilee Clipdriver® and Jubilee Wingspade® are registered trademarks of L Robinson & Co (Gillingham) Limited

We reserve the right, without prior notice, to alter the materials used to accord with new and/or improved specifications.

Please note: All technical data is for comparison purposes only.

There are many variables in each application, such as hose, ferrule and medium, which make it impossible to provide data that is universally accurate. If you have a specific application, please contact us directly for technical assistance.

The finest hose clip
in the world



FM00547

EMS 573195